

SYSTEM DESCRIPTION

Pre-stressing bars are applied for permanent works such as connecting various segments of bridge structures, shear keys for seismic resistance at the connection of segments or girders and piers, and reinforcement of piers that are subject to horizontal pre-stressing forces. They are also applicable for temporary works such as anchoring of temporary steel frame supports and lifting bars for segment launching trusses, and connecting bar segments before pre-stressing. These bars need to have sufficient strength properties to carry the heavy loads of structures and pre-loading to balance the external loads structures are subjected to at a later stage.

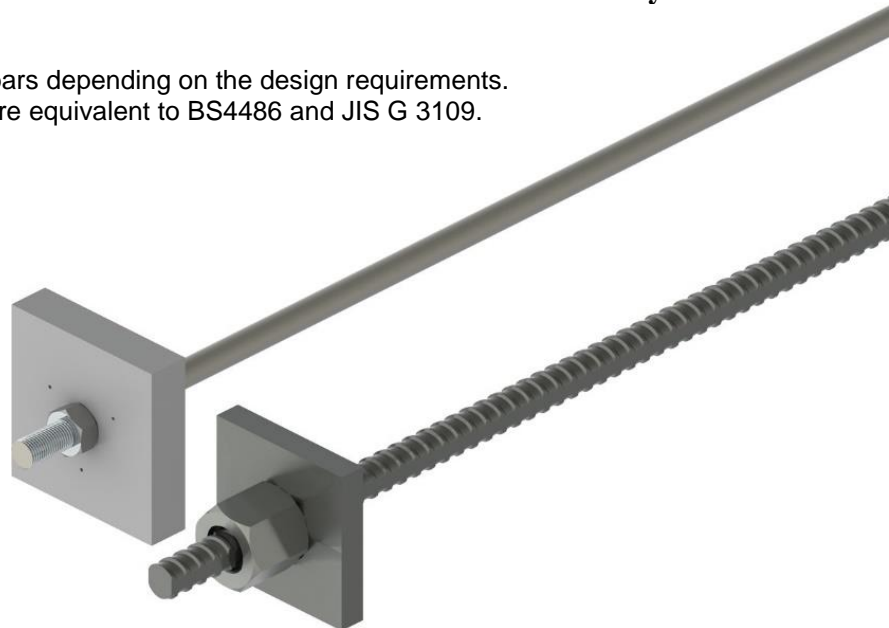

Dextra offers smooth and fully threaded bars depending on the design requirements. The bars comply with ASTM A722, and are equivalent to BS4486 and JIS G 3109.



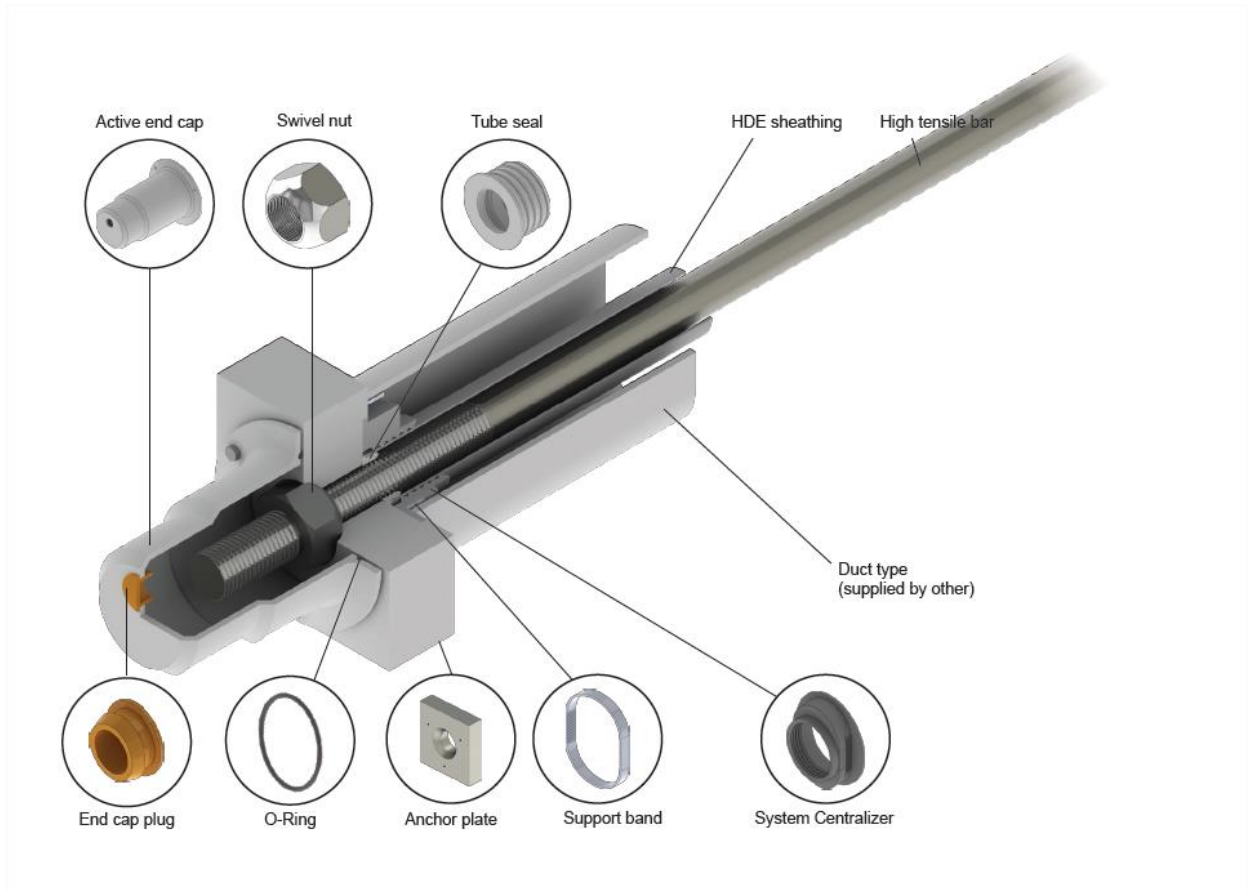

Shear Key's Components

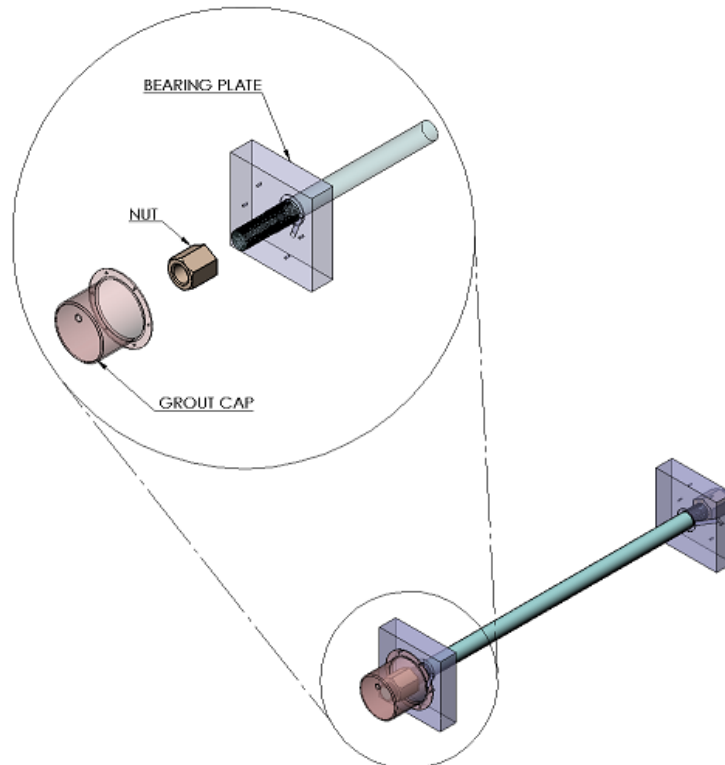

PT Bar's Components

BENEFITS

- Homogeneous material, isotropic and with high tensile strength. Good resilience and resistance to fatigue.
- High impact strength at various temperatures.
- Large plasticity and very high ductility at low temperature.
- Low stress loss on fine thread
- The system can be used in both cases of bonded and unbonded pre-stressing internal and external dismountable.
- Higher elongation compared to traditional products.
- Wide range of corrosion protection such as cement grout, wax injection or coating with plastic heat shrinking sleeve.
- High strength of bars leads to less congestion and ease of installation.
- Ability to detention and re-tension.

DESIGN

Dextra's pre-stressing bars are designed in accordance with following standards;

BS-EN 1992-1-1 (Eurocode 2)
BS-EN 1993-1-1 (Eurocode 3)
ACI 318-08
ASTM A722

APPLICATIONS

- Pre-stressing of concrete structures
- Seismic protection
- Heavy lifting

PRODUCT RANGE



Smooth bars are available in diameters from 28 to 100 mm.

Fully threaded bars are available in diameters 25, 32, 36, 40, 50 and 63.5 mm

All bars can be supplied in lengths up to 11.8 m.

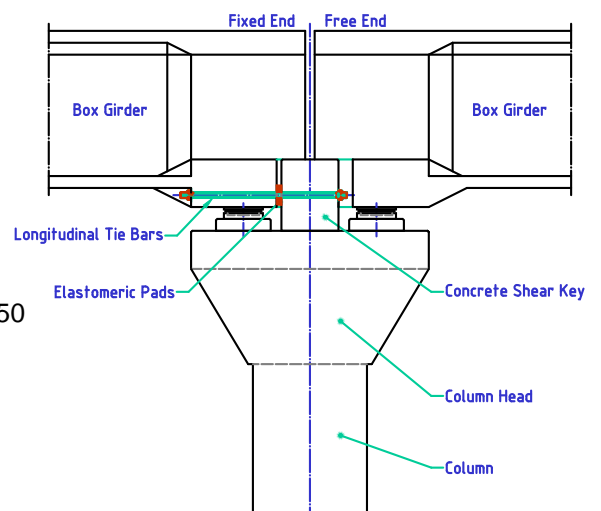
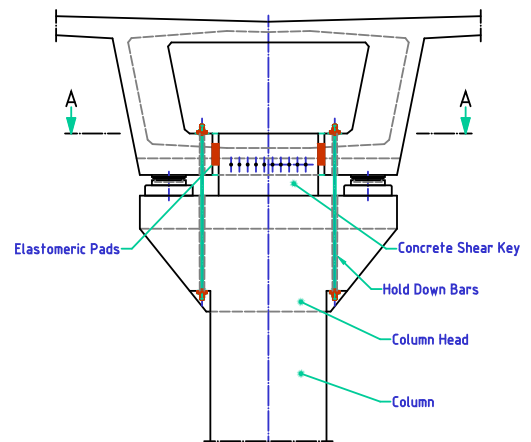

SMOOTH BARS

APPLICATIONS

- Shear Keys for Metro – above ground structure
- Wind Mill for prestressing of concrete foundation
- Bridge construction for temporary or permanent application

STEEL GRADES

Smooth bars are available in three grades as shown in Table 1

Grade	Yield Strength	Tensile strength	E-Modulus	Elongation at failure
	N/mm ²	N/mm ²	N/mm ²	%
835/1030	835	1,030	205,000	12
930/1080	930	1,080	205,000	10
1050/1200	1,050	1,200	205,000	10

Table 1 Mechanical properties of smooth bar

LOAD CAPACITY

Tables 2 show the capacity of bars at 100% of guaranteed strength. The user should compare required ultimate loads to the provided values and working loads to the result of the multiplication of the provided value and specified maximum stressing factor in order to meet these requirements.

Nominal shaft dia. mm	Thread size	Linear weight kg/m	Grade 835/1030		Grade 930/1080		Grade 1050/1200	
			Un-factored Yield Load	Un-factored Ultimate Load	Un-factored Yield Load	Un-factored Ultimate Load	Un-factored Yield Load	Un-factored Ultimate Load
			kN	kN	kN	kN	kN	kN
28.0	M30	4.83	468	577	521	605	589	673
31.0	M33	5.92	579	714	645	749	728	832
34.0	M36	7.13	682	841	760	882	858	980
37.0	M39	8.44	815	1,005	907	1,054	1,025	1,171
40.0	M42	9.86	936	1,155	1,042	1,211	1,177	1,345
43.0	M45	11.40	1,091	1,345	1,215	1,410	1,371	1,567
45.0	M48	12.48	1,230	1,517	1,370	1,591	1,547	1,768
49.0	M52	14.80	1,468	1,811	1,635	1,898	1,846	2,109
53.0	M56	17.32	1,695	2,091	1,888	2,192	2,132	2,436
57.0	M60	20.03	1,972	2,433	2,197	2,551	2,480	2,834
61.0	M64	22.94	2,234	2,756	2,489	2,890	2,810	3,211
65.0	M68	26.04	2,551	3,147	2,841	3,300	3,208	3,666
69.0	M72	29.35	2,889	3,564	3,218	3,737	3,633	4,152
75.0	M78	34.67	3,435	4,237	3,826	4,443	4,319	4,936
80.0	M83	39.45	3,926	4,843	4,373	5,078	4,937	5,642
85.0	M88	44.54	4,450	5,489	4,956	5,755	5,595	6,395
90.0	M93	49.93	5,006	6,175	5,576	6,475	6,295	7,195
95.0	M98	55.63	5,596	6,902	6,232	7,237	7,036	8,042
100.0	M103	61.64	6,218	7,670	6,925	8,042	7,819	8,936

Table 2 Smooth bars load capacity

PHYSICAL PROPERTIES

Nominal dia. mm	Thread size	Linear weight
		kg/m
28.0	M30	4.83
31.0	M33	5.92
34.0	M36	7.13
37.0	M39	8.44
40.0	M42	9.86
43.0	M45	11.40
45.0	M48	12.48
49.0	M52	14.80
53.0	M56	17.32
57.0	M60	20.03
61.0	M64	22.94
65.0	M68	26.04
69.0	M72	29.35
75.0	M78	34.67
80.0	M83	39.45
85.0	M88	44.54
90.0	M93	49.93
95.0	M98	55.63
100.0	M103	61.64

Table 3 : Smooth bars physical properties

ACCESSORIES

The main accessories for PT bars are summarized in Table 4

Accessories	
End caps	 Active end  Passive end
Nuts	 Swivel nut  Hex nut  Round nut
Centralizer	
Anchor plates	 Swivel plate  Flat plate

Table 4 Main Accessories

Nominal dia.	Thread size	Height, m		Flat width s	Corner width e
		Flat Hex nut	Swivel Hex nut		
		mm	mm	mm	mm
28.0	M30	24	30	46	53.1
31.0	M33	26	33	50	57.7
34.0	M36	29	36	55	63.5
37.0	M39	31	39	60	69.3
40.0	M42	34	42	65	75.1
43.0	M45	36	45	70	80.8
45.0	M48	38	48	75	86.6
49.0	M52	42	52	80	92.4
53.0	M56	45	56	85	98.1
57.0	M60	48	60	90	103.9
61.0	M64	51	64	95	109.7
65.0	M68	54	68	100	115.5
69.0	M72	58	72	105	121.2
75.0	M78	62	78	114	131.6
80.0	M83	66	83	117	135.1
85.0	M88	70	88	125	144.3
90.0	M93	74	93	132	152.4
95.0	M98	78	98	140	161.7
100.0	M103	82	103	147	169.7

Table 5 Smooth bar hex nut dimensions

Plates are made of steel grade S355JR as per EN 10025 or equivalent. Nuts are per ISO 898 Part 2.

The use of swivel bearing plates and nuts allow angular deflections of up to 7°.

Connecting couplers and turnbuckles are also available.

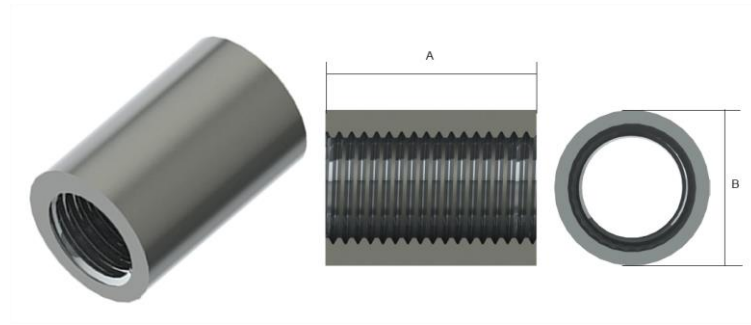

Nominal dia.	Thread size	Grade 835/1030		Grade 930/1080		Grade 1050/1200	
		Length, A	Outside diameter, B	Length, A	Outside diameter, B	Length, A	Outside diameter, B
		mm	mm	mm	mm	mm	mm
28.0	M30	74	45	77	45	85	45
31.0	M33	82	50	85	50	94	50
34.0	M36	89	55	93	55	102	55
37.0	M39	96	60	101	60	111	60
40.0	M42	104	65	108	65	119	65
43.0	M45	111	70	116	70	128	70
45.0	M48	118	75	124	75	136	75
49.0	M52	129	80	134	80	148	80
53.0	M56	138	85	145	85	159	85
57.0	M60	149	90	155	90	171	95
61.0	M64	158	95	166	95	183	100
65.0	M68	169	100	176	105	195	105
69.0	M72	179	110	187	110	207	110
75.0	M78	194	115	203	120	225	120
80.0	M83	207	130	217	130	240	130
85.0	M88	220	130	230	140	255	140
90.0	M93	233	140	244	140	270	150
95.0	M98	246	150	257	150	285	160
100.0	M103	259	160	271	160	300	160

Table 6 Smooth bar coupler dimensions

FULLY THREADED BARS

APPLICATIONS

- Bridge Construction:
 - Temporary or permanent stressing of segments
 - Lifting bars

STEEL GRADES

Fully threaded bar are available in three grades as shown in Table 7

Grade	Yield Strength	Tensile strength	E-Modulus	Elongation at failure
	N/mm ²	N/mm ²	N/mm ²	%
830/1030	830	1,030	200,000	6
930/1080	930	1,080	200,000	6
1080/1230	1,080	1,230	200,000	6

Table 7 Mechanical properties of fully threaded bar

LOAD CAPACITY

Tables 8 show the capacity of bars at 100% of guaranteed strength. The user should compare required ultimate loads to the provided values and working loads to the result of the multiplication of the provided value and specified maximum stressing factor in order to meet these requirements.

Nominal diameter	Cross-section area	Linear weight	Grade 830/1030		Grade 930/1080		Grade 1080/1230	
			Yield load	Ultimate load	Yield load	Ultimate load	Yield load	Ultimate load
mm	mm ²	kg/m	kN	kN	kN	kN	kN	kN
25	491	4.1	408	506	457	531	531	604
32	804	6.65	668	829	748	869	869	990
36	1,018	8.41	845	1,049	947	1,100	1,100	1,253
40	1,257	10.34	1,043	1,295	1,169	1,358	1,358	1,546
50	1,964	16.28	1,630	2,023	1,827	2,121	2,121	2,416
63.5	3,167	24.86	2,629	3,262	2,945	3,420	3,420	3,895

Table 8 Fully threaded bars load capacity

PHYSICAL PROPERTIES

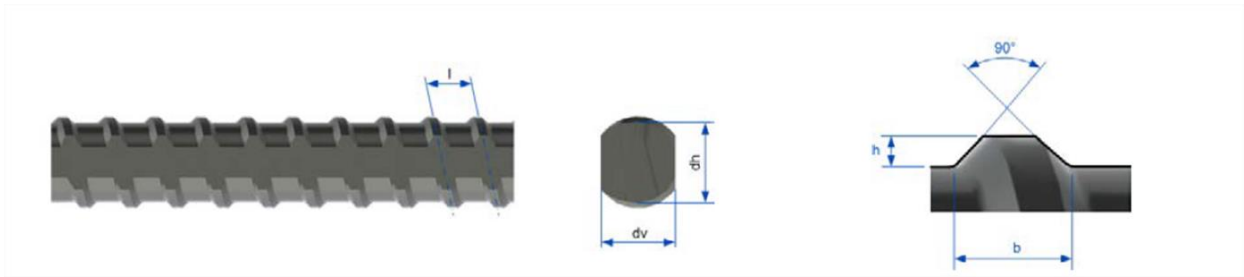

Nominal dia.	Dv	Dh	h	b	i	Nominal Section Area	Linear weight
mm	mm	mm	mm	mm	mm	mm	kg/m
25.00	25.00	25.00	1.60	6.00	12.00	490.90	4.10
32.00	32.00	32.00	2.00	7.00	16.00	804.20	6.65
36.00	36.00	36.00	2.20	8.00	18.00	1018.00	8.41
40.00	40.00	40.00	2.50	8.00	20.00	1256.60	10.34
50.00	50.00	50.00	3.00	9.00	24.00	1963.50	16.28
63.50	63.00	63.50	3.00	12.00	22.00	3167.00	26.20

Table 9 Fully threaded bars physical properties

ACCESSORIES

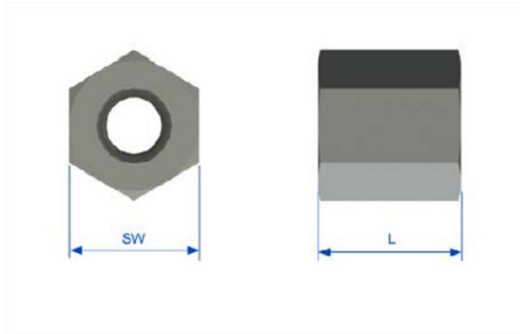

Nominal dia.	L	SW	Weight
mm	mm	mm	kg/m
25.00	54.00	50.00	0.65
32.00	72.00	65.00	1.45
36.00	80.00	65.00	1.65
40.00	100.00	70.00	2.09
50.00	110.00	80.00	2.71
63.50	115.00	100.00	4.58

Table 10 Fully threaded bar : Flat hex nut

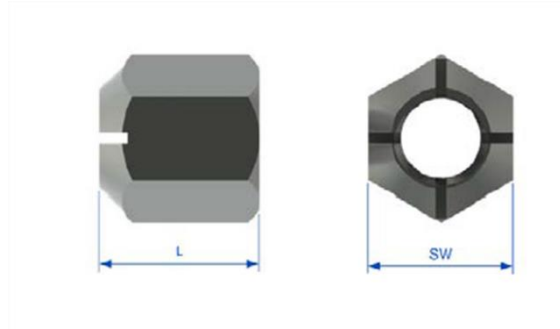

Normal dia.	L	SW	Weight
mm	mm	mm	kg/m
25.00	54.00	50.00	0.60
32.00	72.00	65.00	1.35
36.00	80.00	65.00	1.50
40.00	100.00	70.00	2.00
50.00	110.00	80.00	2.60
63.50	115.00	100.00	5.00

Table 11 Fully threaded bar : Spherical hex nut

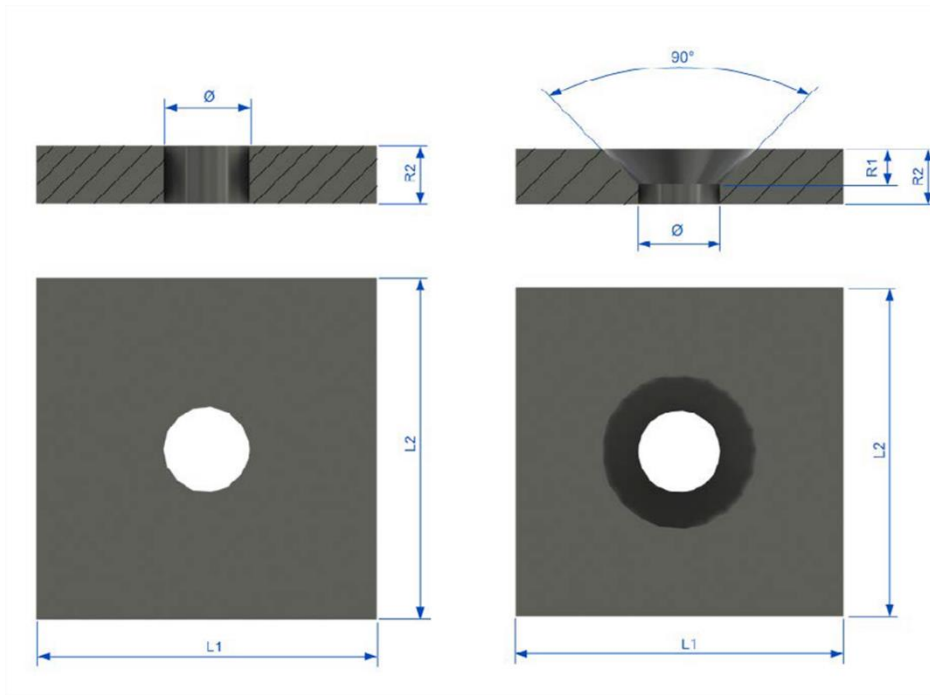

Nominal dia.	L1	L2	R1	R2	Hole diameter	Weight
mm	mm	mm	mm	mm	mm	kg/m
25.00	120.00	120.00	13.50	20.00	35.00	2.10
32.00	140.00	140.00	15.50	24.00	45.00	3.50
36.00	150.00	150.00	15.00	30.00	50.00	5.00
40.00	160.00	160.00	15.00	30.00	55.00	6.00
50.00	200.00	200.00	17.50	50.00	65.00	14.00
63.50	240.00	240.00	20.00	50.00	80.00	21.80

Table 12 Fully threaded bar : Bearing plate dimensions

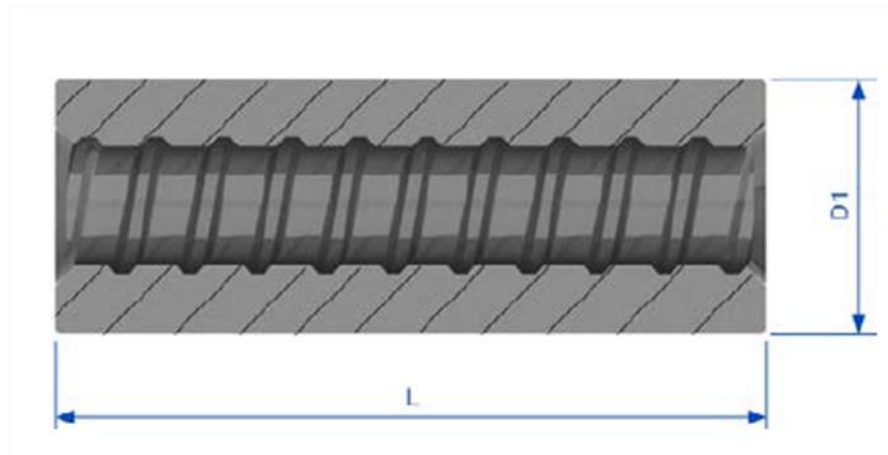

Nominal dia.	L1	D1	Weight
mm	mm	mm	kg/m
25.00	54.00	50.00	0.60
32.00	72.00	65.00	1.35
36.00	80.00	65.00	1.50
40.00	100.00	70.00	2.00
50.00	110.00	80.00	2.60
63.50	115.00	100.00	5.00

Table 13 Fully threaded bar : Coupler dimensions

QUALITY ASSURANCE

Every component of the Dextra pre-stressing bar is manufactured under consistent quality assurance as required by ISO 9001 certification. Load-bearing components are all individually marked with a lot number that enables full traceability. Traceability of bars is achieved through both the mill certificates and the certificates of compliance provided together with the delivery notes. The customer is advised to keep a proper record of the location of each batch. Full project files are provided to the client together with the goods.

A Certificate of Compliance with related quality and test reports are provided with each delivery.

A final dossier comprised of all drawings, calculation notes, and quality documents can be provided at the end of the supply period, upon request.



SURFACE FINISH

There is no specific surface finish required for pre-stressing bars; specific coatings are available upon request.

CORROSION PROTECTION

The smooth bars are normally supplied in a HDPE tube injected with grease. However, they may be protected from corrosion by various means; to be specified by the client: cement grout, wax, plastic shrink films, paint, etc. These various types of protection may be applied on site or in a workshop.

INSTALLATION SEQUENCE

Installation sequence of Dextra's pre-stressing bars is dependent on application purposes, pre-stressing, post-tensioning, shear key, heavy lifting etc. The installer should follow the Technical Specification in the Project Contract Documents. Dextra is committed to providing service during installation.

DISCLAIMER

Galvanization of the smooth bars may be possible, provided that the temperature of the hot dip does not exceed 450°C and the dipping time is less than 15 minutes.

If the bars are going to be tensioned, they should not be epoxy-painted as the epoxy layer may crack during tensioning.

Fully threaded bar properties should be compared against the design requirements such as stress loss and fatigue properties prior to application.

No welding/heating should be attempted on Dextra's pre-stressing bars without consulting a welding engineer and without the approval of the Design Engineer. Dextra assumes no liability or guarantees for any of its products that are welded/heated without prior written authorization.

CUTTING

Pre-stressing bars can be cut with a friction circular blade but gas cutting is strictly prohibited.

HANDLING AND STORAGE

Pre-stressing bars are delivered in bundles. Threads are protected by thick fabric or plastic pipe. The bars are slightly oil-coated to limit corrosion during shipping and must be cleaned by solvent before use. According to their superior ductility, bars are less likely to sustain damage due to poor handling. Use of a spreader bar for lifting is not compulsory but is recommended. Do not store pre-stressing bars directly on the ground: use wooden sleepers, in a covered area.

INFORMATION FOR INQUIRIES

For each inquiry, customers are requested to provide the following information to Dextra :

- 1) The required diameter of bar.
- 2) The required working and ultimate load.
- 3) The length of the bar from face to face of concrete and the length of the threads.
- 4) The Bill of Quantity
- 5) The bar surface finished if any.
- 6) The type of corrosion protection required.
- 7) The accessories required.
- 8) The details of the surface on which the plates will bear.
- 9) The type of structure where the bars will be used, temporary or permanent.
- 10) The application (Join a drawing or a sketch of the bars in place and Technical Specification).
- 11) The tensioning load.
- 12) The delivery date and location.

PROVISIONS FOR CHANGES

As we strive for continuous improvement of all our products, Dextra reserves the right to modify the contents of this document at any time without prior notice.